

DATA SHEET

TDA1521A

2 x 6 W hi-fi audio power amplifier

Product specification
File under Integrated Circuits, IC01

July 1994

2 x 6 W hi-fi audio power amplifier**TDA1521A****GENERAL DESCRIPTION**

The TDA1521A is a dual hi-fi audio power amplifier encapsulated in a 9-lead plastic power package. The device is especially designed for mains fed applications (e.g. stereo tv sound and stereo radio).

Features

- Requires very few external components
- Input muted during power-on and off
(no switch-on or switch-off clicks)
- Low offset voltage between output and ground
- Excellent gain balance between channels
- Hi-fi according to IEC 268 and DIN 45500
- Short-circuit-proof
- Thermally protected.

QUICK REFERENCE DATA**Stereo applications**

Supply voltage range	V_P	$\pm 7,5$ to $\pm 21,0$ V
Output power at THD = 0,5%, $V_P = \pm 12$ V	P_o	typ. 6 W
Voltage gain	G_V	typ. 30 dB
Gain balance between channels	ΔG_V	typ. 0,2 dB
Ripple rejection	SVRR	typ. 60 dB
Channel separation	α	typ. 70 dB
Noise output voltage	$V_{no(rms)}$	typ. 70 μ V

PACKAGE OUTLINE

TDA1521A: 9-lead single in-line; plastic power (SOT 110B); SOT110-1; 1996 July 22.

2 x 6 W hi-fi audio power amplifier

TDA1521A

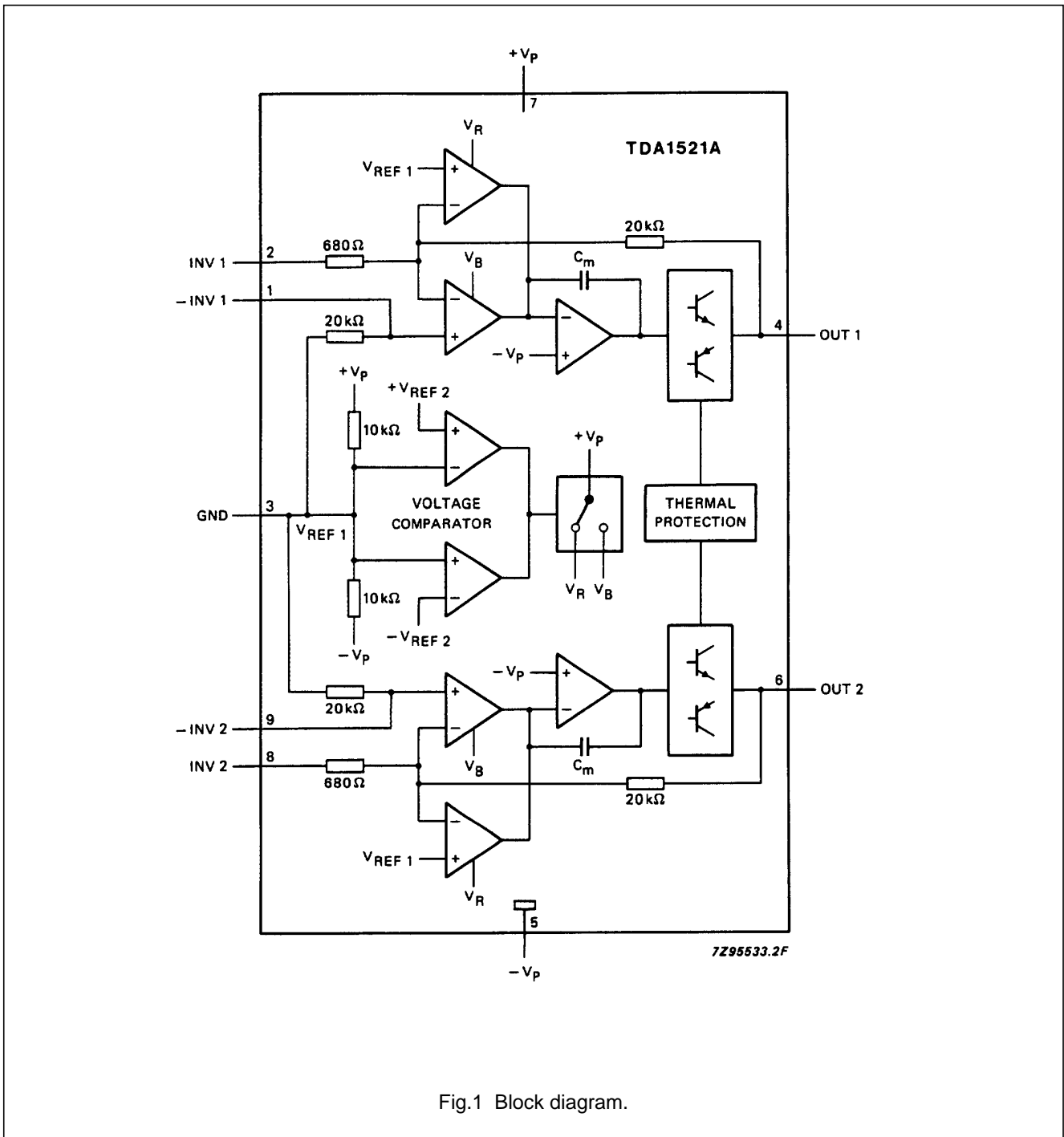

Fig.1 Block diagram.

2 x 6 W hi-fi audio power amplifier

TDA1521A

PINNING

1	-INV1	non-inverting input 1	5	-V _P	negative supply (symmetrical) ground (asymmetrical)
2	INV1	inverting input 1	6	OUT2	output 2
3	GND	ground (symmetrical) ½ V _P (asymmetrical)	7	+ V _P	positive supply
4	OUT1	output 1	8	INV2	inverting input 2
			9	-INV2	non-inverting input 2

FUNCTIONAL DESCRIPTION

This hi-fi stereo power amplifier is designed for mains fed applications. The circuit is designed for both symmetrical and asymmetrical power supply systems. An output power of 2 × 6 watts (THD = 0,5%) can be delivered into an 8 Ω load with a symmetrical power supply of ± 12 V.

The gain is fixed internally at 30 dB. Internal gain fixing gives low gain spread and very good balance between the amplifiers (0,2 dB).

A special feature of this device is a mute circuit which suppresses unwanted input signals during switching on and off. Referring to Fig.12, the 100 µF capacitor creates a time delay when the voltage at pin 3 is lower than an internally fixed reference voltage. During the delay the amplifiers remain in their DC operating mode but are isolated from the non-inverting inputs on pins 1 and 9.

Two thermal protection circuits are provided, one monitors the average junction temperature and the other the instantaneous temperature of the power transistors. Both protection circuits activate at 150 °C allowing safe operation to a maximum junction temperature of 150 °C without added distortion.

RATINGS

Limiting values in accordance with the Absolute Maximum System (IEC 134)

PARAMETER	CONDITIONS	SYMBOL	MIN.	MAX.	UNIT
Supply voltage	pin 7	$V_P = V_{7-3}$	–	+21	V
	pin 5	$-V_P = V_{5-3}$	–	-21	V
Non-repetitive peak output current	pins 4 and 6	I_{OSM}	–	4	A
Total power dissipation	see Fig.2	P_{tot}			
Storage temperature range		T_{stg}	-55	+ 150	°C
Junction temperature		T_j	–	150	°C
Short-circuit time: outputs short-circuited to ground (full signal drive)	see note 1 symmetrical power supply asymmetrical power supply	t_{sc} t_{sc}	–	1	hour
			–	1	hour

Note

1. For asymmetrical power supplies (at short circuiting of the load) the maximum supply voltage is limited to $V_P = 28$ V.

2 x 6 W hi-fi audio power amplifier

TDA1521A

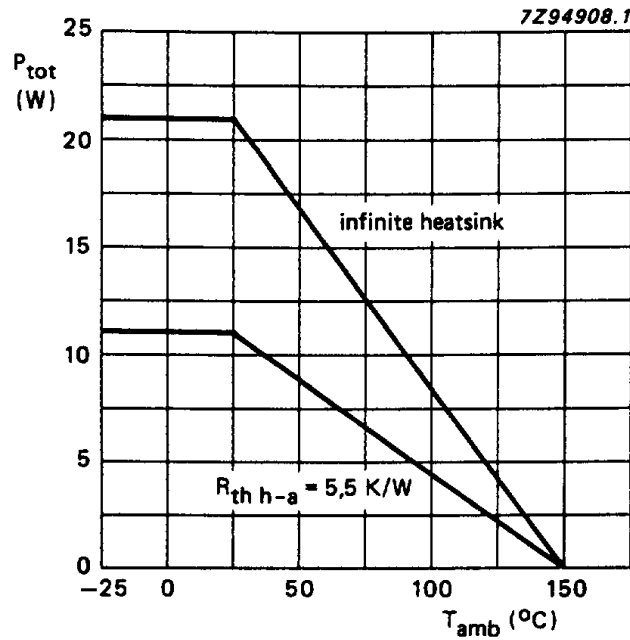

Fig.2 Power derating curve.

THERMAL RESISTANCE

From junction to case

$$R_{th\ j-c} = 6\ K/W$$

HEATSINK DESIGN EXAMPLE

With derating of 6 K/W, the value of heatsink thermal resistance is calculated as follows:

given $R_L = 8\ \Omega$ and $V_P = \pm 12\ V$, the measured maximum dissipation is 7,8 W; then, for a maximum ambient temperature of 60 °C, the required thermal resistance of the heatsink is

$$R_{th\ h-a} = \frac{150 - 60}{7,8} - 6 = 5,5\ K/W$$

Note: The metal tab (heatsink) has the same potential as pin 5 ($-V_P$).

2 x 6 W hi-fi audio power amplifier

TDA1521A

CHARACTERISTICS

PARAMETER	CONDITIONS	SYMBOL	MIN.	TYP.	MAX.	UNIT
Supply voltage range						
operating mode		V_P	$\pm 7,5$	$\pm 12,0$	$\pm 20,0$	V
input mute mode		V_P	$\pm 2,0$	–	$\pm 5,8$	V
Repetitive peak						
output current		I_{ORM}	–	–	2,2	A
Operating mode: symmetrical power supply; test circuit as per Fig.11; $V_P = \pm 12$ V; $R_L = 8 \Omega$; $T_{amb} = 25$ °C; $f = 1$ kHz						
Total quiescent current	without R_L	I_{tot}	18	40	70	mA
Output power	THD = 0,5%	P_o	5	6	–	W
	THD = 10%	P_o	6,5	8,0	–	W
Total harmonic distortion	$P_o = 4$ W	THD	–	0,15	0,2	%
Power bandwidth	THD = 0,5% note 1	B		20 to 16 k		Hz
Voltage gain		G_v	29	30	31	dB
Gain balance		ΔG_v	–	0,2	1,0	dB
Noise output voltage (r.m.s. value); unweighted (20 Hz to 20 kHz)	$R_S = 2$ k Ω	$V_{no(rms)}$	–	70	140	μ V
Input impedance		$ Z_i $	14	20	26	k Ω
Ripple rejection	note 2	SVRR	40	60	–	dB
Channel separation	$R_S = 0 \Omega$	α	46	70	–	dB
Input bias current		I_{ib}	–	0,3	–	μ A
DC output offset voltage	with respect to ground	V_{OFF}	–	30	200	mV
Input mute mode: symmetrical power supply; test circuit as per Fig.11; $V_P = \pm 4$ V; $R_L = 8 \Omega$; $T_{amb} = 25$ °C; $f = 1$ kHz						
Total quiescent current	without R_L	I_{tot}	9	30	40	mA
Output voltage	$V_i = 600$ mV	V_{out}	–	0,6	1,8	mV
Noise output voltage (r.m.s. value); unweighted (20 Hz to 20 kHz)	$R_S = 2$ k Ω	$V_{no(rms)}$	–	70	140	μ V
Ripple rejection	note 2	SVRR	35	55	–	dB
DC output offset voltage	with respect to ground	V_{OFF}	–	40	200	mV

2 x 6 W hi-fi audio power amplifier

TDA1521A

PARAMETER	CONDITIONS	SYMBOL	MIN.	TYP.	MAX.	UNIT
Operating mode: asymmetrical power supply; test circuit as per Fig.12;						
$V_P = 24\text{ V}$; $R_L = 8\ \Omega$; $T_{\text{amb}} = 25\text{ }^\circ\text{C}$; $f = 1\text{ kHz}$						
Total quiescent current		I_{tot}	18	40	70	mA
Output power	THD = 0,5%	P_o	5	6	–	W
	THD = 10%	P_o	6,5	8	–	W
Total harmonic distortion	$P_o = 4\text{ W}$	THD	–	0,13	0,2	%
Power bandwidth	THD = 0,5%			40 to		
	note 1	B		16 k		Hz
Voltage gain		G_v	29	30	31	dB
Gain balance		ΔG_v	–	0,2	1,0	dB
Noise output voltage (r.m.s. value); unweighted (20 Hz to 20 kHz)						
	$R_S = 2\text{ k}\Omega$	$V_{\text{no(rms)}}$	–	70	140	μV
Input impedance		$ Z_i $	14	20	26	$\text{k}\Omega$
Ripple rejection		SVRR	35	44	–	dB
Channel separation	$R_S = 0\ \Omega$	α	–	45	–	dB

Notes to the characteristics

1. Power bandwidth at $P_{o\text{ max}} -3\text{ dB}$.
2. Ripple rejection at $R_S = 0\ \Omega$, $f = 100\text{ Hz}$ to 20 kHz ; ripple voltage = 200 mV (r.m.s. value) applied to positive or negative supply rail.

2 x 6 W hi-fi audio power amplifier

TDA1521A

APPLICATION INFORMATION

Input mute circuit

The input mute circuit operates only during switching on and off of the supply voltage. The circuit compares the $\frac{1}{2}$ supply voltage (at pin 3) with an internally fixed reference voltage (V_{ref}), derived directly from the supply voltage. When the voltage at pin 3 is lower than V_{ref} the non-inverting inputs (pins 1 and 9) are disconnected from the amplifier. The voltage at pin 3 is determined by an internal voltage divider and the external 100 μ F capacitor.

During switching on, a time delay is created between the reference voltage and the voltage at pin 3, during which the input terminal is disconnected, (as illustrated in Fig.3).

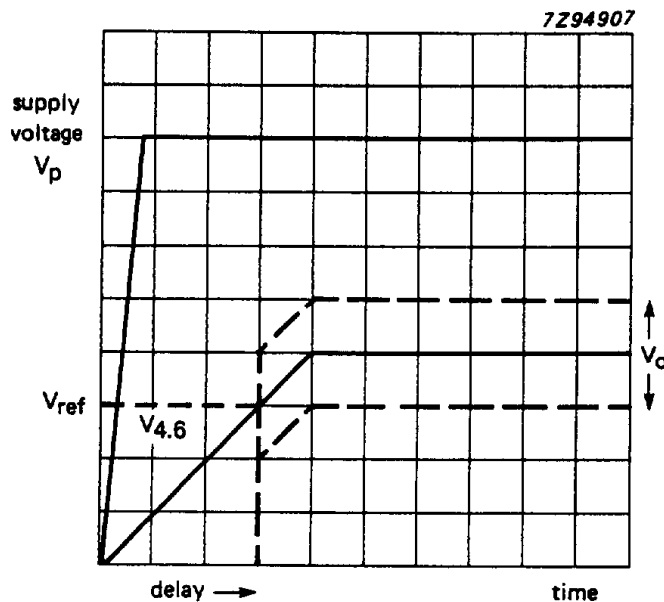

Fig.3 Input mute circuit; time delay.

2 x 6 W hi-fi audio power amplifier

TDA1521A

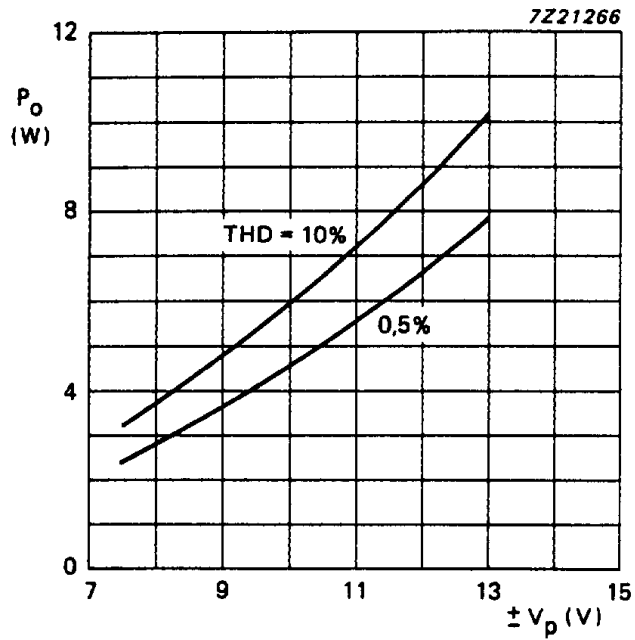

Fig.4 Output power as a function of supply voltage; symmetrical supply; $R_L = 8 \Omega$; $f = 1 \text{ kHz}$.

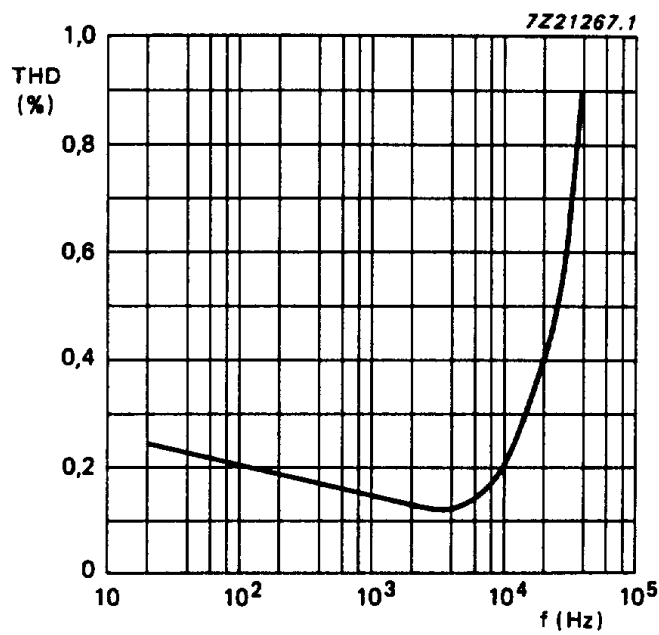

Fig.5 Distortion as a function of frequency; symmetrical supply; $V_p = \pm 12 \text{ V}$; $R_L = 8 \Omega$; $P_o = 3 \text{ W}$.

2 x 6 W hi-fi audio power amplifier

TDA1521A

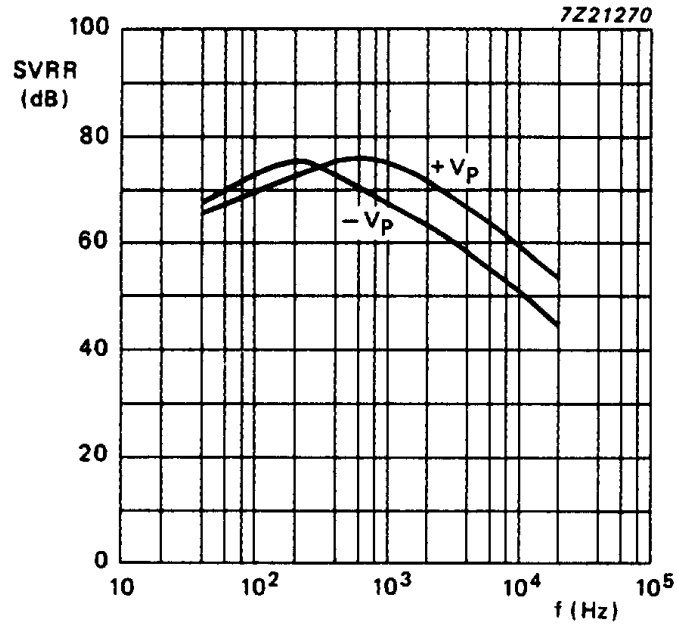

Fig.6 Supply voltage ripple rejection; symmetrical supply, $V_P = \pm 12$ V; $V_{RR} = 200$ mV.

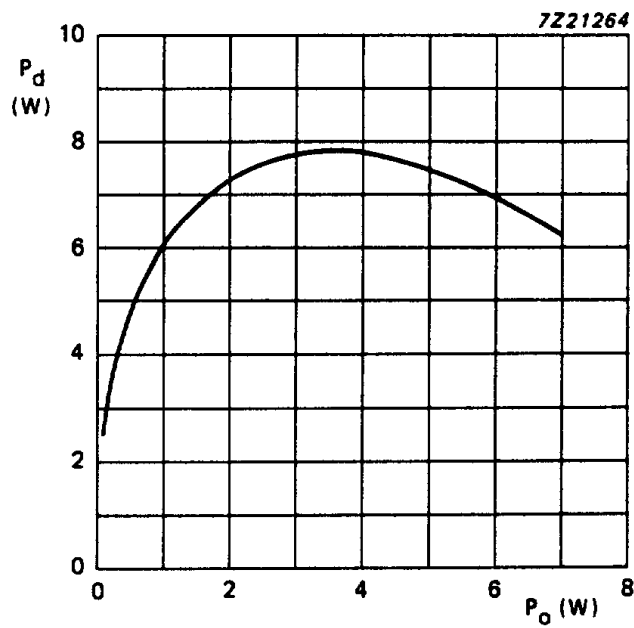

Fig.7 Power dissipation as a function of output power; asymmetrical supply; $V_S = 24$ V; $R_L = 8 \Omega$; $f = 1$ kHz.

2 x 6 W hi-fi audio power amplifier

TDA1521A

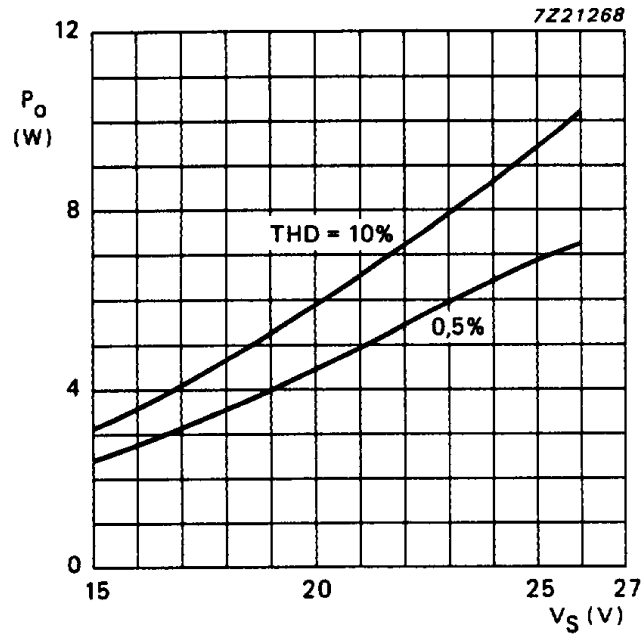

Fig.8 Output power as a function of supply voltage; asymmetrical supply; $R_L = 8 \Omega$; $f = 1 \text{ kHz}$.

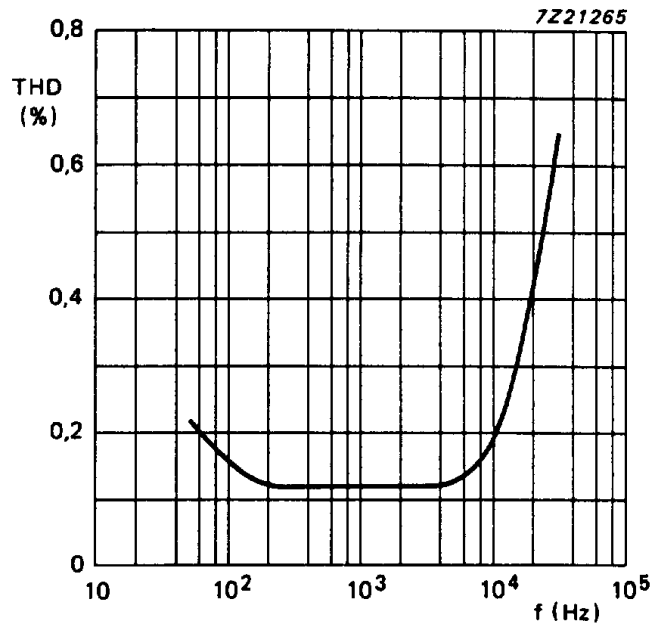

Fig.9 Distortion as a function of frequency; asymmetrical supply; $V_S = 24 \text{ V}$; $R_L = 8 \Omega$; $P_o = 3 \text{ W}$.

2 x 6 W hi-fi audio power amplifier

TDA1521A

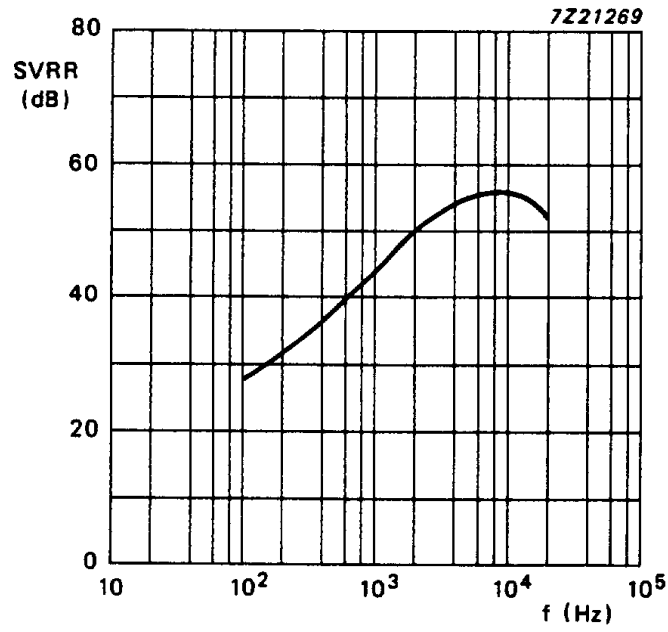
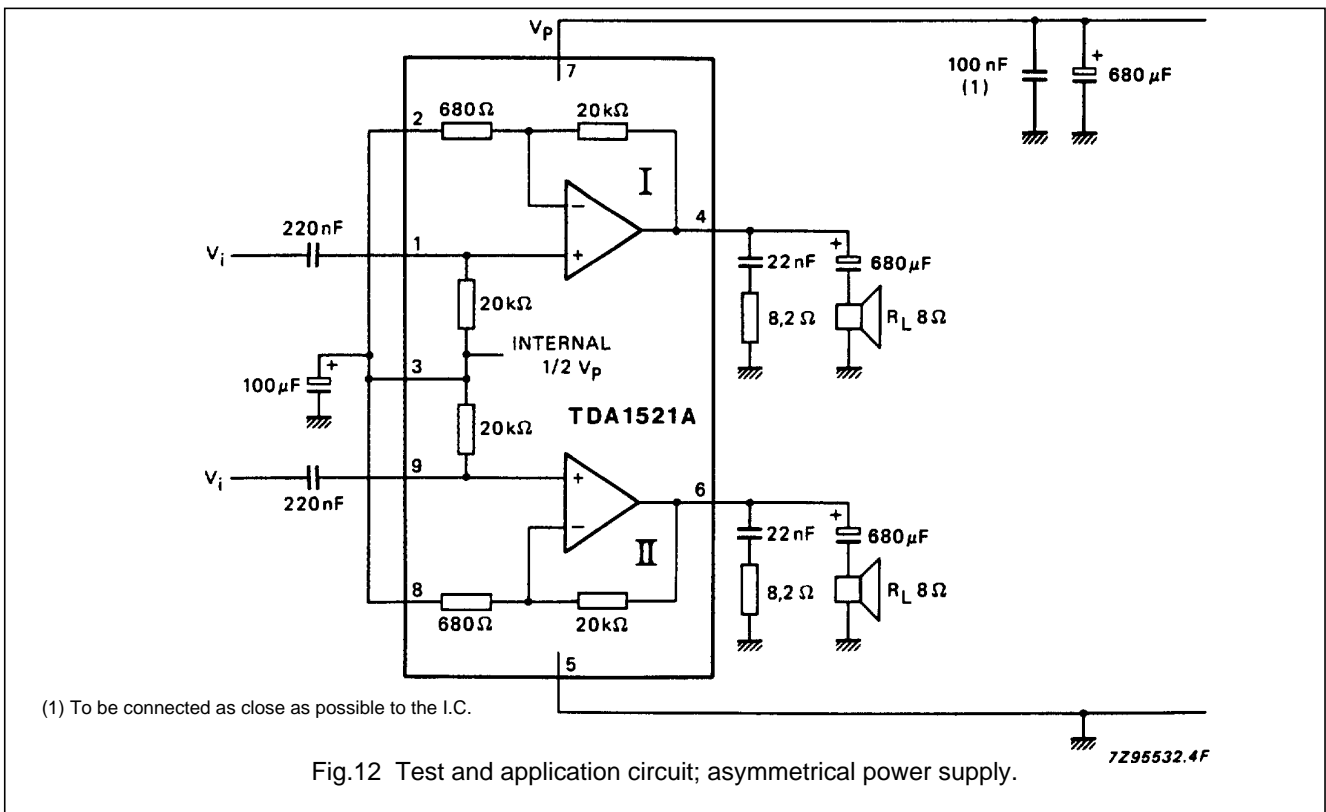
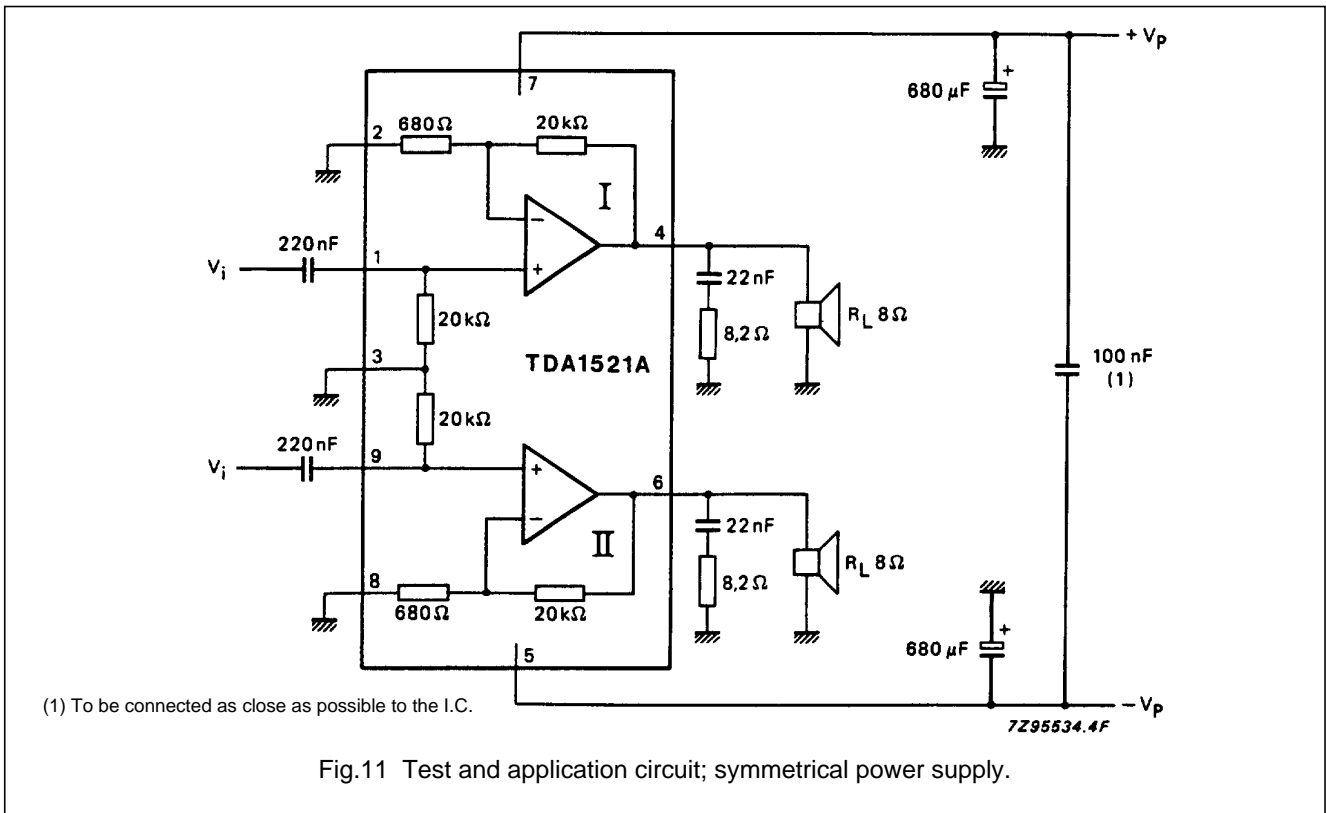

Fig.10 Supply voltage ripple rejection; asymmetrical supply; $V_S = 24\text{ V}$; $V_{RR} = 200\text{ mW}$.

2 x 6 W hi-fi audio power amplifier

TDA1521A



2 x 6 W hi-fi audio power amplifier

TDA1521A

PACKAGE OUTLINE

SIL9MPF: plastic single in-line medium power package with fin; 9 leads

SOT110-1

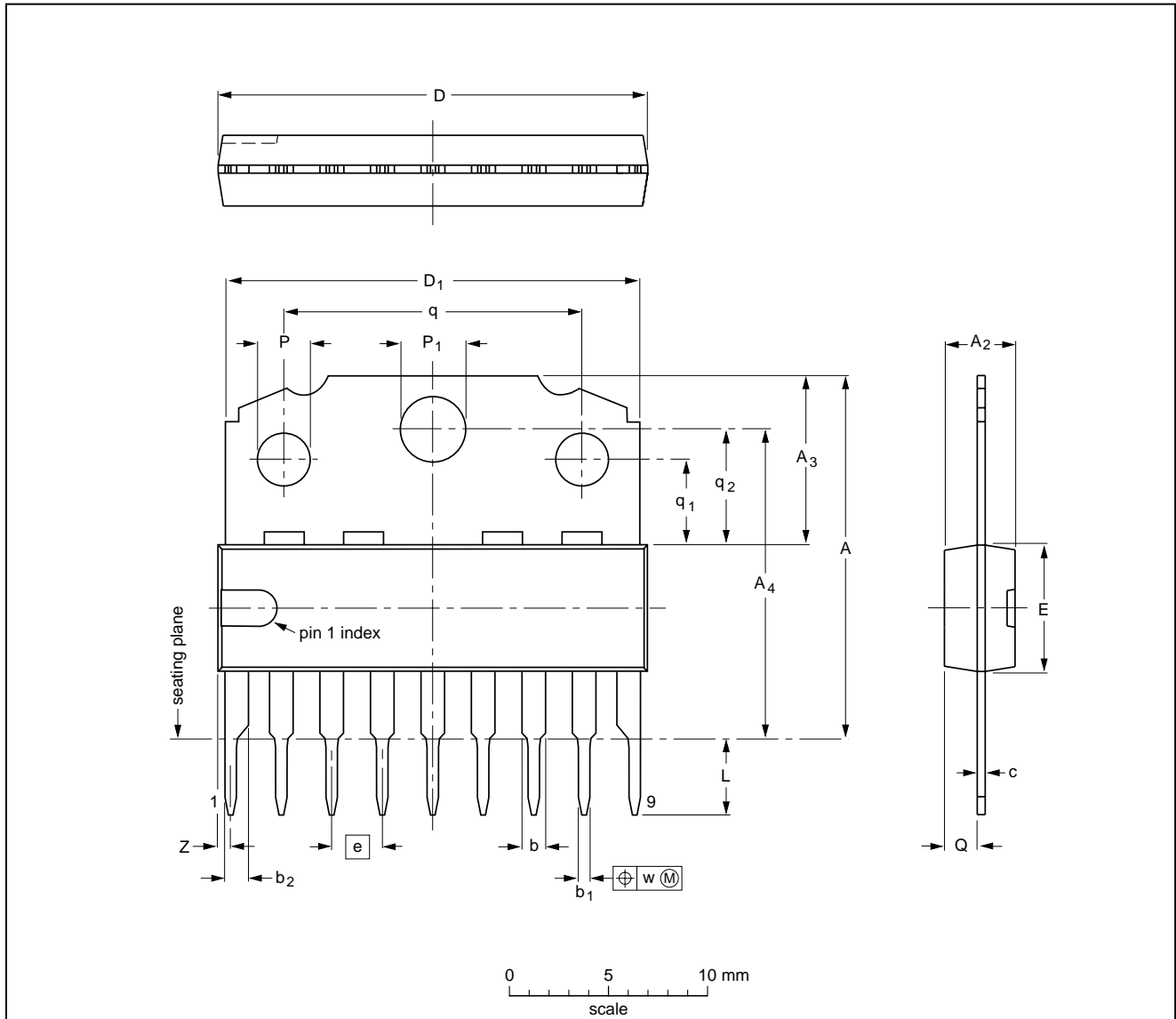

DIMENSIONS (mm are the original dimensions)

UNIT	A	A ₂ max.	A ₃	A ₄	b	b ₁	b ₂	c	D ⁽¹⁾	D ₁	E ⁽¹⁾	e	L	P	P ₁	Q	q	q ₁	q ₂	w	Z ⁽¹⁾ max.
mm	18.5 17.8	3.7	8.7 8.0	15.8 15.4	1.40 1.14	0.67 0.50	1.40 1.14	0.48 0.38	21.8 21.4	21.4 20.7	6.48 6.20	2.54	3.9 3.4	2.75 2.50	3.4 3.2	1.75 1.55	15.1 14.9	4.4 4.2	5.9 5.7	0.25	1.0

Note

1. Plastic or metal protrusions of 0.25 mm maximum per side are not included.

OUTLINE VERSION	REFERENCES				EUROPEAN PROJECTION	ISSUE DATE
	IEC	JEDEC	EIAJ			
SOT110-1						92-11-17 95-02-25

2 x 6 W hi-fi audio power amplifier

TDA1521A

SOLDERING**Introduction**

There is no soldering method that is ideal for all IC packages. Wave soldering is often preferred when through-hole and surface mounted components are mixed on one printed-circuit board. However, wave soldering is not always suitable for surface mounted ICs, or for printed-circuits with high population densities. In these situations reflow soldering is often used.

This text gives a very brief insight to a complex technology. A more in-depth account of soldering ICs can be found in our "IC Package Databook" (order code 9398 652 90011).

Soldering by dipping or by wave

The maximum permissible temperature of the solder is 260 °C; solder at this temperature must not be in contact with the joint for more than 5 seconds. The total contact time of successive solder waves must not exceed 5 seconds.

The device may be mounted up to the seating plane, but the temperature of the plastic body must not exceed the specified maximum storage temperature ($T_{stg\ max}$). If the printed-circuit board has been pre-heated, forced cooling may be necessary immediately after soldering to keep the temperature within the permissible limit.

Repairing soldered joints

Apply a low voltage soldering iron (less than 24 V) to the lead(s) of the package, below the seating plane or not more than 2 mm above it. If the temperature of the soldering iron bit is less than 300 °C it may remain in contact for up to 10 seconds. If the bit temperature is between 300 and 400 °C, contact may be up to 5 seconds.

DEFINITIONS

Data sheet status	
Objective specification	This data sheet contains target or goal specifications for product development.
Preliminary specification	This data sheet contains preliminary data; supplementary data may be published later.
Product specification	This data sheet contains final product specifications.
Limiting values	
Limiting values given are in accordance with the Absolute Maximum Rating System (IEC 134). Stress above one or more of the limiting values may cause permanent damage to the device. These are stress ratings only and operation of the device at these or at any other conditions above those given in the Characteristics sections of the specification is not implied. Exposure to limiting values for extended periods may affect device reliability.	
Application information	
Where application information is given, it is advisory and does not form part of the specification.	

LIFE SUPPORT APPLICATIONS

These products are not designed for use in life support appliances, devices, or systems where malfunction of these products can reasonably be expected to result in personal injury. Philips customers using or selling these products for use in such applications do so at their own risk and agree to fully indemnify Philips for any damages resulting from such improper use or sale.